

# TRANSLATION OF THE SPECIAL MODELS • OPTIONS ELECTRIC CHAIN HOIST TYPE GP

The instruction manual of the GP-models (9500.9002.1) is the basis for the special models. This attachment is part of the instruction manual. Only added or corrected chapters are listed.





# Table of contents

## Special models

Model GPH (Handy) .....	4
Model GPR (corrosion resistant model).....	8
Model GPS (synchronised chain hoists).....	12
Model GPK (low headroom version).....	15

## Options

Model GP with frequency inverter (FU) .....	18
Model GP as an ATEX model (D/G) .....	21
Model GP with radio remote control .....	24
Model GP with temperature monitoring .....	27
Model GP with operating data counter .....	28

## Special models

---

### Model GPH (Handy)

#### 1 Description

Due to mounting the control handle directly on the load thread it enables a one-handed and accurate guiding of transport goods. Suitable for left and right-handed people. A quick fastening of loads is possible due to available load suspension devices (hook fixed, hook rotatable, threaded bolts M12). At the handy telescope model, an angle offers the possibility for eccentric loads to fix special constructions of load suspension devices. Optionally, a slack chain switch is available.

**Model GPH 500 handy chain model (see figure 1-1):**

The control handle is fixed at the chain end. The standard lifting height is 4 m.

**Model GPHT 500 handy telescope model (see figure 1-2):**

The telescope guidance allows the suspension of eccentric loads (max. torque 150 Nm). The lifting process takes place through the chain on the inside of the telescope guidance. The control handle is fixed at the chain end. For a soft start, these models are also available as frequency controlled model (FU). The standard lifting heights are 1200 mm, 1500 mm and 2000 mm.

Figure 1-1

Figure 1-2



The frequency controlled model is delivered with a factory setting of 15 Hz for the first speed and 87 Hz for the second speed. The first speed can be reduced to a minimum of 8 Hz.

**Load suspension device (see figure 1-3):**

- Hook fixed (1), hook rotatable (2), threaded bolts M12 (3)
- Angle for eccentric load (4 only for GPHT)

**Options:**

- Slack chain switch (see figure 1-4)
- Frequency inverter (FU)
- Temperature monitoring
- Operating data counter

Figure 1-3

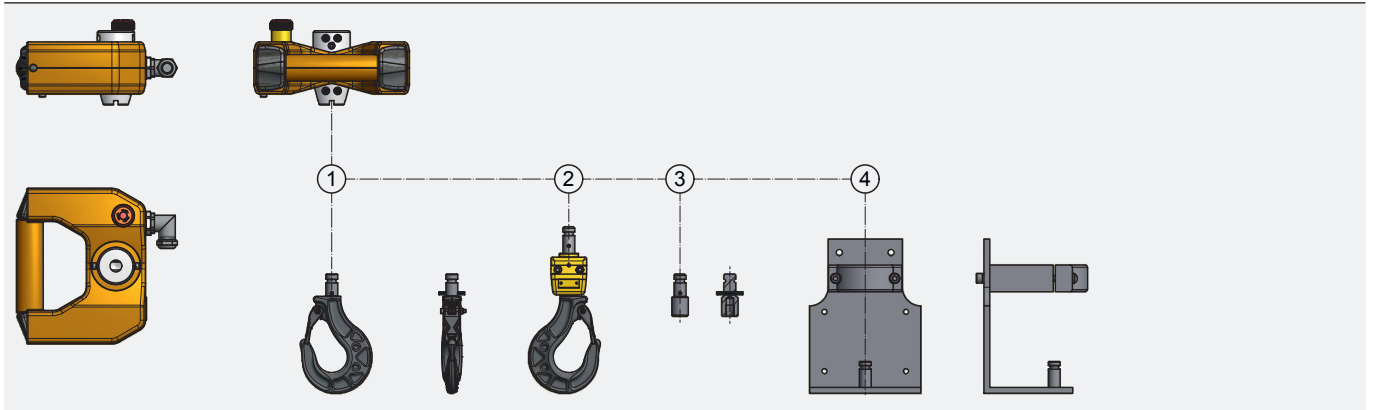
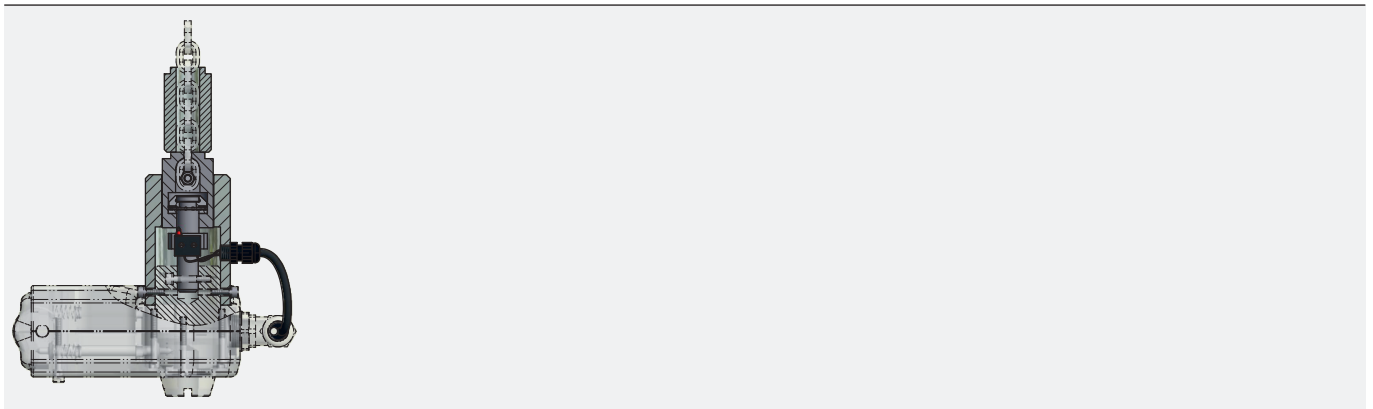

Figure 1-4



## 2 Start-up

### 2.2 Connecting

#### 2.2.1 Electrical connection

The models GPH and GPHT are delivered fully equipped. The final positions are set optimally in the factory. Thus, only the main voltage (L1, L2, L3 and PE) needs to be connected to the corresponding terminals. When replacing the control coil, the strands are to be connected according to figure 1-5.



The rotation direction of the motor is to be controlled.



The chain can be guided precisely due to handy handle as control switch. An additional strain relief is not necessary. During operation, it needs to be ensured that the control coil is always turned back into the starting position.

Figure 1-5

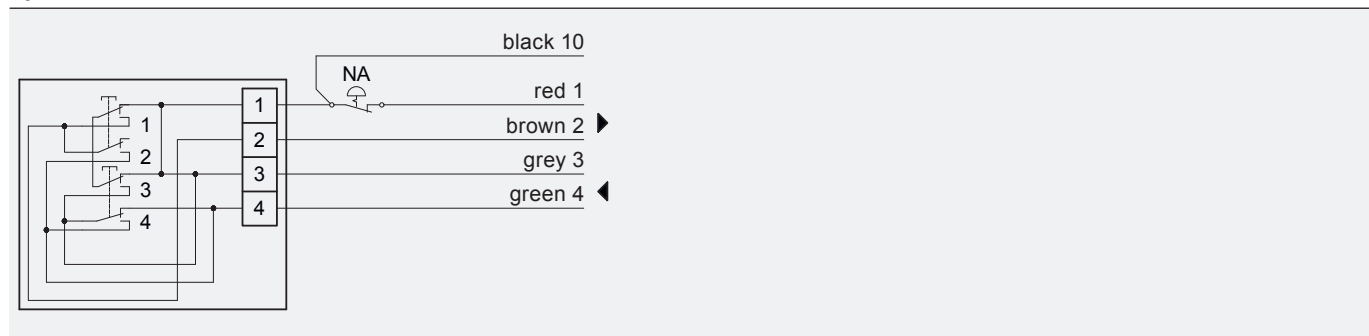

## 3 Care and maintenance

### 3.2 Care and maintenance

#### 3.2.4 Load chain

The load chain must be checked periodically for wear. For the handy telescope model, the chain container must be removed for visual check, cleaning and lubricating the chain. The telescope guidance is also to be controlled to the same way.

# 5 Appendix

## 5.1 Technical data

Table 5-1 Technical data GPH (three-phase version)

ISO (FEM) classification	M3 (1Bm) 150 s/h 25% duty	M4 (1Am) 180 s/h 30% duty	M5 (2m) 240 s/h 40% duty	M6 (3m) 300 s/h 50% duty	M7 (4m) 360 s/h 60% duty	M7 (4m) 360 s/h 60% duty	Lifting speed 50 Hz	Lifting speed 60 Hz	Motor type	No. of chain falls	Dead weight 4 m lift	Mains fuse (400 V, delayed)
Types	Capacity [kg]						[m/min]	[m/min]			[kg]	[A]
GPH 500/NF	-	-	500	400	320	250	8/2	9.6/2.4	80 B 8/2	1	25	6
GPH 500/SF	-	-	250	200	160	125	16/4	19.2/4.8	80 B 8/2	1	25	6

Table 5-2 Technical data GPH (three-phase version)

ISO (FEM) classification	M7 (4m) 360 s/h 60% duty	M7 (4m) 360 s/h 60% duty	M7 (4m) 360 s/h 60% duty	M7 (4m) 360 s/h 60% duty	M7 (4m) 360 s/h 60% duty	M7 (4m) 360 s/h 60% duty	Lifting speed 8/87 Hz	Lifting speed 15/87 Hz	Motor type	No. of chain falls	Dead weight 4 m lift	Mains fuse (400 V, delayed)
Types	Capacity [kg]						[m/min]	[m/min]			[kg]	[A]
GPH 500/NL FU	-	-	500	400	320	320	0.7/6.9	1.4/6.9	80 B 4	1	26	6
GPH 500/N FU	-	-	500	400	320	320	1.3/13.9	2.6/13.9	80 A 2	1	26	6

Table 5-3 Technical data GPHT (three-phase version)

ISO (FEM) classification	M3 (1Bm) 150 s/h 25% duty	M4 (1Am) 180 s/h 30% duty	M5 (2m) 240 s/h 40% duty	M6 (3m) 300 s/h 50% duty	M7 (4m) 360 s/h 60% duty	M7 (4m) 360 s/h 60% duty	Lifting speed 50 Hz	Lifting speed 60 Hz	Motor type	No. of chain falls	Dead weight 1.5 m lift	Mains fuse (400 V, delayed)
Types	Capacity [kg]						[m/min]	[m/min]			[kg]	[A]
GPHT 500/NF	-	-	250	200	160	-	8/2	9.6/2.4	80 B 8/2	1	52	6
GPHT 500/SF	-	-	125	100	80	-	16/4	19.2/4.8	80 B 8/2	1	52	6

Table 5-4 Technical data GPHT (three-phase version)

ISO (FEM) classification	M7 (4m) 360 s/h 60% duty	M7 (4m) 360 s/h 60% duty	M7 (4m) 360 s/h 60% duty	M7 (4m) 360 s/h 60% duty	M7 (4m) 360 s/h 60% duty	M7 (4m) 360 s/h 60% duty	Lifting speed 8/87 Hz	Lifting speed 15/87 Hz	Motor type	No. of chain falls	Dead weight 1.5 m lift	Mains fuse (400 V, delayed)
Types	Capacity [kg]						[m/min]	[m/min]			[kg]	[A]
GPHT 500/NL FU	-	-	250	200	160	160	0.7/6.9	1.4/6.9	80 B 4	1	53	6
GPHT 500/N FU	-	-	250	200	160	160	1.3/13.9	2.6/13.9	80 A 2	1	53	6

# Model GPR (corrosion resistant model)

## 1 Description

Due to corrosion resistant model of all parts in the load thread, the chain hoist is especially suitable for applications in the food sector, cleaning rooms but also in aggressive surroundings with salt water or dirt. The cathodic dip-paint coating of the aluminium parts prevents spalling of colour and is a good protecting against corrosion. Grease filling in the gear consists of food compatible grease. Optionally, the chain lubricating oil is available in food compatible model. The chain hoists GPR are equipped with a corrosion resistant round steel chain. Since this chain does not reach the strength values of the standard chain, the lifting capacity values are reduced.

### Model GPR (see figure 1-1):

For a soft start, these models are also available as frequency controlled model (FU).

Figure 1-1





**Load suspension device:**

- Load hook 1 fall (see figure 1-3), load hook 2 falls (see figure 1-4)

**Options:**

- Food compatible chain lubricating oil (Food Lub)
- Hook suspension
- Frequency inverter (FU)
- Radio remote control
- Temperature monitoring
- Operating data counter

Figure 1-3

Figure 1-4



## 2 Start-up

### 2.2 Connecting

#### 2.2.2 Load chain



- Only use original chains (round steel chain).
- Oil chain for start-up along entire length.

**Operation 1 fall (see figure 2-1) and operation 2 falls (see figure 2-2):**

Figure 2-1

Figure 2-2

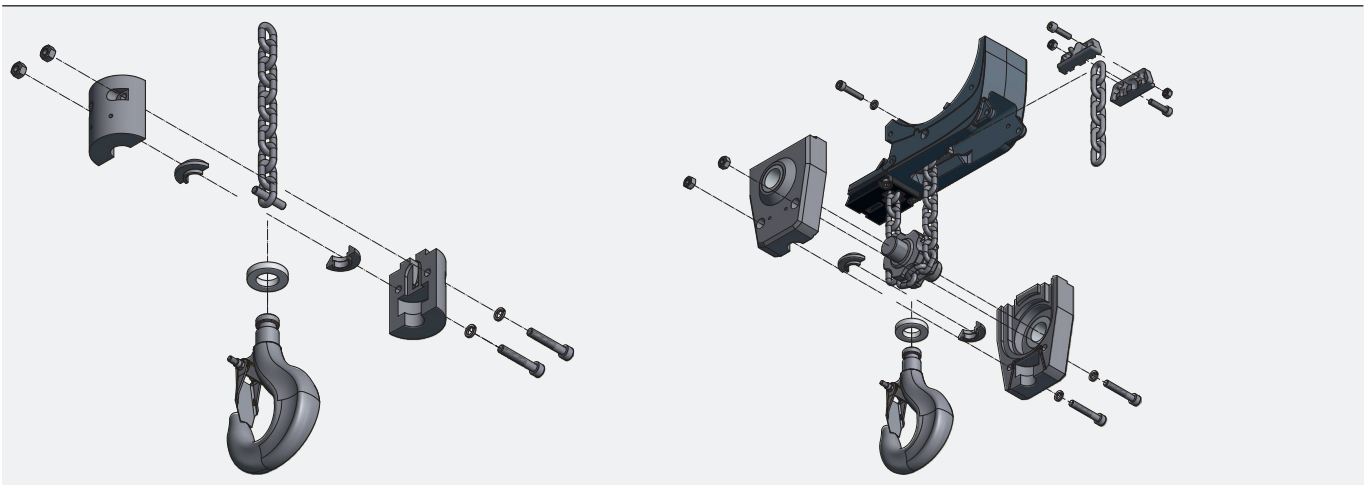

# 3 Care and maintenance

## 3.2 Care and maintenance

### 3.2.4 Load chain

The load chain should be periodically checked for abrasion. The wear dimensions are different compared to the GP models. The check is based upon three measurements: see accepted wear factors (table 3-1) and measurement points (figure 3-1).

Table 3-1 Load chain wear values

Term		GPR 500	GPR 1000		
Chain type d x t	[mm]	5 x 15.3	7 x 22		
Tolerances according to DIN 685, part 5, DIN EN 818-7					
1. Measurement over 11 chain links, a = 11t	[mm]	171.6	246.8		
2. Measurement over 1 chain link, 1t	[mm]	16.0	23.1		
3. Measurement of the chain link diameter dm = d1 + d2 / 2 (dm min. = 0.9 x d)	[mm]	4.5	6.3		

Figure 3-1

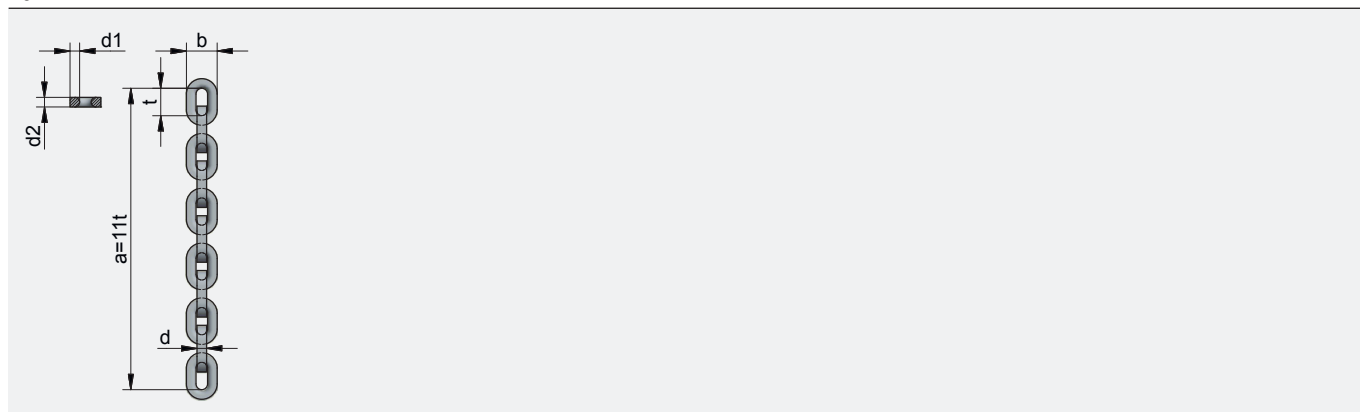

# 5 Appendix

## 5.1 Technical data

Table 5-1 Technical data GPR (three-phase version)

ISO (FEM) classification	M3 (1Bm) 150 s/h 25% duty	M4 (1Am) 180 s/h 30% duty	M5 (2m) 240 s/h 40% duty	M6 (3m) 300 s/h 50% duty	M7 (4m) 360 s/h 60% duty	M7 (4m) 360 s/h 60% duty	Lifting speed 50 Hz	Lifting speed 60 Hz	Motor type	No. of chain falls	Dead weight 3 m lift	Mains fuse (400 V, delayed)
Types	Capacity [kg]						[m/min]	[m/min]			[kg]	[A]
GPR 500/1NF	-	320	250	-	-	-	8/2	9.6/2.4	80 B 8/2	1	26	6
GPR 500/1SF	-	160	125	-	-	-	16/4	19.2/4.8	80 B 8/2	1	26	6
GPR 500/1N	-	320	250	-	-	-	8	9.6	80 B 2	1	26	6
GPR 500/2NF	-	630	500	-	-	-	4/1	4.8/1.2	80 B 8/2	2	28	6
GPR 500/2SF	-	-	-	-	-	-	-	-	-	-	-	-
GPR 500/2N	-	630	500	-	-	-	4	4.8	80 B 2	2	28	6
GPR 1000/1NF	-	630	500	-	-	-	8/2	9.6/2.4	100 B 8/2	1	62	10
GPR 1000/1N	-	630	500	-	-	-	8	9.6	100 B 2	1	62	10
GPR 1000/2NF	-	1250	1000	-	-	-	4/1	4.8/1.2	100 B 8/2	2	66	10
GPR 1000/2N	-	1250	1000	-	-	-	4	4.8	100 B 2	2	66	10

Table 5-2 Technical data GPR (three-phase version)

ISO (FEM) classification	M3 (1Bm) 150 s/h 25% duty	M4 (1Am) 180 s/h 30% duty	M5 (2m) 240 s/h 40% duty	M5 (2m) 240 s/h 40% duty	M5 (2m) 240 s/h 40% duty	M5 (2m) 240 s/h 40% duty	Lifting speed 8/87 Hz	Lifting speed 15/87 Hz	Motor type	No. of chain falls	Dead weight 3 m lift	Mains fuse (400 V, delayed)
Types	Capacity [kg]						[m/min]	[m/min]			[kg]	[A]
GPR 500/1NL FU	-	320	250	-	-	-	0.7/6.9	1.3/6.9	80 B 4	1	27	6
GPR 500/1N FU	-	320	250	-	-	-	1.3/13.9	2.4/13.9	80 B 2	1	27	6
GPR 500/2NL FU	-	630	500	-	-	-	0.3/3.5	0.6/3.5	80 B 4	2	29	6
GPR 500/2N FU	-	630	500	-	-	-	0.7/6.9	1.3/6.9	80 B 2	2	29	6
GPR 1000/1NL FU	-	-	-	630	500	-	0.7/6.9	1.3/6.9	90 B 4	1	63	10
GPR 1000/1N FU	-	-	-	630	500	-	1.3/13.9	2.4/13.9	90 B 2	1	63	10
GPR 1000/2NL FU	-	-	-	1250	1000	-	0.3/3.5	0.6/3.5	90 B 4	2	67	10
GPR 1000/2N FU	-	-	-	1250	1000	-	0.7/6.9	1.3/6.9	90 B 2	2	67	10

Table 5-3 Technical data GPR (one-phase version)

ISO (FEM) classification	M3 (1Bm) 150 s/h 25% duty	M4 (1Am) 180 s/h 30% duty	M5 (2m) 240 s/h 40% duty	M5 (2m) 240 s/h 40% duty	M5 (2m) 240 s/h 40% duty	M5 (2m) 240 s/h 40% duty	Lifting speed 50 Hz	Lifting speed 60 Hz	Motor type	No. of chain falls	Dead weight 3 m lift	Mains fuse (230 V, delayed)
Types	Capacity [kg]						[m/min]	[m/min]			[kg]	[A]
GPR 500/1NL 1Ph	-	320	250	-	-	-	4	4.8	80 A 4	1	26	10
GPR 500/1N 1Ph	-	-	250	-	-	-	8	9.6	80 A 4	1	26	10
GPR 500/2NL 1Ph	-	630	500	-	-	-	2	2.4	80 A 4	2	28	10
GPR 500/2N 1Ph	-	-	500	-	-	-	4	4.8	80 A 4	2	28	10

# Model GPS (synchronised chain hoists)

## 1 Description

Two electric chain hoists, connected with a rigid shaft, guarantee an absolute parallel lifting and lowering of long transport goods. Due to the central control, both motors are switched simultaneously. At the direct outlet of the chain allows the lifting of twice the nominal load of the single chain hoists. The motors are protected against overloading by temperature monitoring. The rotatable eyebolt suspensions allow driving on curves. The customer defines the distance between the two load hooks in advance. Distances between 700 mm and 5000 mm are available. From 3000 mm on, the connection shaft is supported additionally.

### Model GPS (see figure 1-1):

For a soft start, these models are also available as frequency controlled model (FU). The chain hoist with integrated control is labelled with A, the opposite one with B.

Figure 1-1

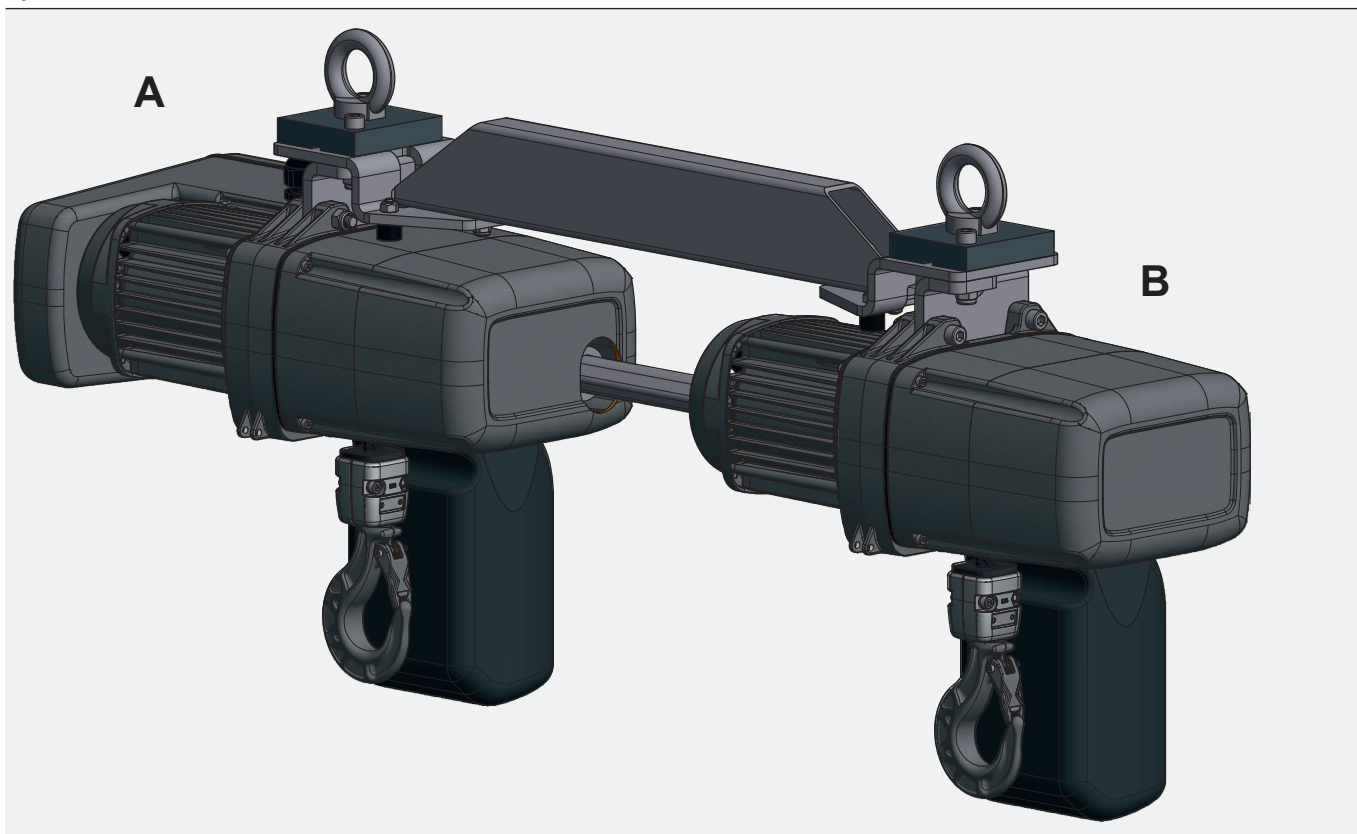

### Options:

- Frequency inverter (FU)
- Radio remote control
- Operating data counter



The protection class is reduced to IP 33.

## 2 Start-up

### 2.2 Connecting

#### 2.2.1 Electrical connection

The models GPS are delivered fully equipped. The two load chains are levelled and the final positions are optimally set. Both electric chain hoists are electrically connected. The contactor control and connection terminals are located in electric chain hoist A. The connection of the main voltage takes place with the terminals L1, L2, L3 and PE, whereas the control voltage is connected with the terminals 1, 2, 3, 4, 10. At the standard control cable, the strands are labelled correspondingly.

Additional instructions are described in the instruction manual GP in chapter 2.2.1.



Observe the rotating connection shaft.

#### 2.2.2 Load chain



The lifting capacity is to be followed according to the labelling of the single load hooks.

#### 2.2.3 Limit switch

The limit switch is located in electric chain hoist B. Due to the mechanical connection, it fulfils its function for both electric chain hoists. The setting takes place as described in instruction manual GP in chapter 2.2.3 and figure 2-16.

## 3 Care and maintenance

### 3.1 General guidelines for maintenance and servicing



For replacing the connection shaft, it is mandatory to contact the qualified personnel of the manufacturer.

# 5 Appendix

## 5.1 Technical data

Table 5-1 Technical data GPS (three-phase version)

ISO (FEM) classification	M3 (1Bm) 150 s/h 25% duty	M4 (1Am) 180 s/h 30% duty	M5 (2m) 240 s/h 40% duty	M6 (3m) 300 s/h 50% duty	M7 (4m) 360 s/h 60% duty	M7 (4m) 360 s/h 60% duty	Lifting speed 50 Hz	Lifting speed 60 Hz	Motor type	No. of chain falls	Dead weight 3 m lift	Mains fuse (400 V, delayed)
Types	Capacity [kg]						[m/min]	[m/min]			[kg]	[A]
GPS 500/1NF	-	2x630	2x500	2x400	2x320	2x250	8/2	9.6/2.4	2x80 B 8/2	1	50	10
GPS 500/1SF	-	2x320	2x250	2x200	2x160	2x125	16/4	19.2/4.8	2x80 B 8/2	1	50	10
GPS 500/2NF	-	2x1250	2x1000	2x800	-	-	4/1	4.8/1.2	2x80 B 8/2	2	54	10
GPS 1000/1NF	-	2x1250	2x1000	2x800	2x630	2x500	8/2	9.6/2.4	2x100 B 8/2	1	122	10
GPS 1000/1SF	-	2x630	2x500	2x400	-	-	16/4	19.2/4.8	2x100 B 8/2	1	122	10
GPS 1000/2NF	-	2x2500	2x2000	2x1600	2x1250	2x1000	4/1	4.8/1.2	2x100 B 8/2	2	130	10

Table 5-2 Technical data GPS FU (three-phase version)

ISO (FEM) classification	M6 (3m) 300 s/h 50% duty	M7 (4m) 360 s/h 60% duty	M7 (4m) 360 s/h 60% duty	M7 (4m) 360 s/h 60% duty	M7 (4m) 360 s/h 60% duty	M7 (4m) 360 s/h 60% duty	Lifting speed 8/87 Hz	Lifting speed 15/87 Hz	Motor type	No. of chain falls	Dead weight 3 m lift	Mains fuse (400 V, delayed)
Types	Capacity [kg]						[m/min]	[m/min]			[kg]	[A]
GPS 500/1NL FU	2x630	2x500	2x400	2x320	2x250	-	0.7/6.9	1.3/6.9	2x80 B 4	1	51	10
GPS 500/1N FU	2x630	2x500	2x400	2x320	2x250	-	1.3/13.9	2.4/13.9	2x80 B 2	1	51	10
GPS 500/2NL FU	2x1250	2x1000	2x800	-	-	-	0.3/3.5	0.6/3.5	2x80 B 4	2	55	10
GPS 500/2N FU	2x1250	2x1000	2x800	-	-	-	0.7/6.9	1.3/6.9	2x80 B 2	2	55	10
GPS 1000/1NL FU	2x1250	2x1000	2x800	2x630	2x500	-	0.7/6.9	1.3/6.9	2x100 B 4	1	123	10
GPS 1000/1N FU	2x1250	2x1000	2x800	2x630	2x500	-	1.3/13.9	2.4/13.9	2x100 B 2	1	123	10
GPS 1000/2NL FU	2x2500	2x2000	2x1600	2x1250	2x1000	-	0.3/3.5	0.6/3.5	2x100 B 4	2	131	10
GPS 1000/2N FU	2x2500	2x2000	2x1600	2x1250	2x1000	-	0.7/6.9	1.3/6.9	2x100 B 2	2	131	10

## Model GPK (low headroom version)

### 1 Description

By redirecting the chain with the low headroom version, the construction height can be reduced significantly. The model GPK is available for all three-phase versions. The models GPK are delivered fully equipped. A standard electric chain hoist is integrated in the redirecting construction.

**Model GPK in a standard model (see figure 1-1) and in extended model (see figure 1-2):**

For a soft start, these models are also available as frequency controlled model (FU).

Figure 1-1

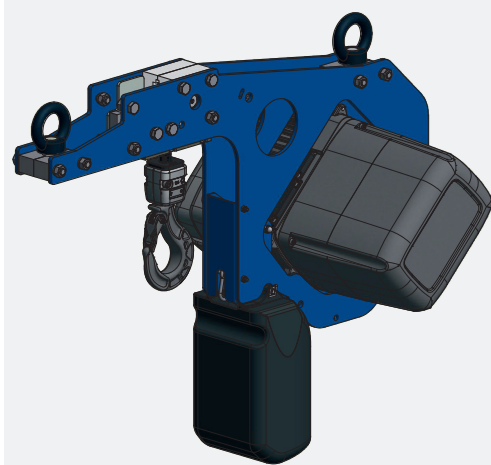
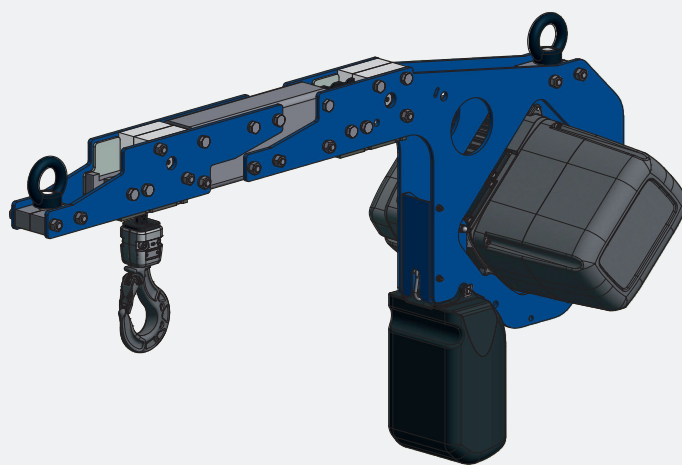

Figure 1-2



#### Options:

- Hook suspension (see figure 1-3)
- Frequency inverter (FU)
- Radio remote control
- Temperature monitoring
- Operating data counter

Figure 1-3

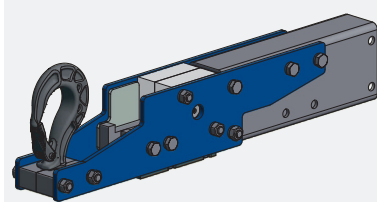

## 2 Start-up

### 2.2 Connecting

#### 2.2.1 Electrical connection

The electrical connection takes place as described in the instruction manual GP in chapter 2.2.1. The strain relief of the control switch takes place according to figure 2-1.

#### 2.2.4 Chain container

The chain container is assembled depending on the model: Plastic container according to figure 2-2 or textile container according to figure 2-3.

Figure 2-1



Figure 2-2

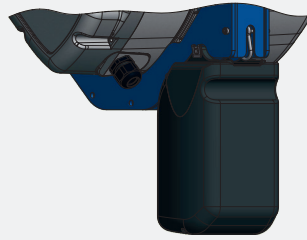
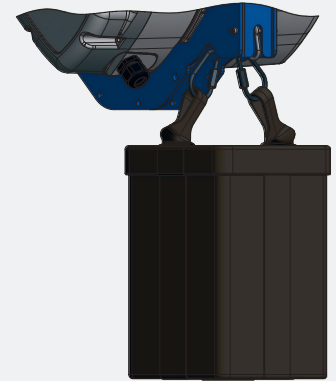

Figure 2-3





# 5 Appendix

## 5.1 Technical data

Table 5-1 Technical data GPK (three-phase version)

ISO (FEM) classification	M3 (1Bm) 150 s/h 25% duty	M4 (1Am) 180 s/h 30% duty	M5 (2m) 240 s/h 40% duty	M6 (3m) 300 s/h 50% duty	M7 (4m) 360 s/h 60% duty	M7 (4m) 360 s/h 60% duty	Lifting speed 50 Hz	Lifting speed 60 Hz	Motor type	No. of chain falls	Dead weight 3 m lift	Mains fuse (400 V, delayed)
Types	Capacity [kg]						[m/min]	[m/min]			[kg]	[A]
GPK 500/1NF	-	500	400	320	250	-	8/2	9.6/2.4	80 B 8/2	1	50	10
GPK 500/1SF	-	250	200	160	125	-	16/4	19.2/4.8	80 B 8/2	1	50	10
GPK 500/1N	-	500	400	320	250	-	8	9.6	80 B 2	1	50	10
GPK 500/2NF	-	1000	800	630	500	-	4/1	4.8/1.2	80 B 8/2	2	54	10
GPK 500/2N	-	1000	800	630	500	-	4	4.8	80 B 2	2	54	10

Table 5-2 Technical data GPK (three-phase version)

ISO (FEM) classification	M3 (1Bm) 150 s/h 25% duty	M4 (1Am) 180 s/h 30% duty	M5 (2m) 240 s/h 40% duty	M6 (3m) 300 s/h 50% duty	M7 (4m) 360 s/h 60% duty	M7 (4m) 360 s/h 60% duty	Lifting speed 8/87 Hz	Lifting speed 15/87 Hz	Motor type	No. of chain falls	Dead weight 3 m lift	Mains fuse (400 V, delayed)
Types	Capacity [kg]						[m/min]	[m/min]			[kg]	[A]
GPK 500/1NL FU	-	500	400	320	250	-	0.7/6.9	1.4/6.9	80 B 4	1	50	10
GPK 500/1N FU	-	500	400	320	250	-	1.3/13.9	2.6/13.9	80 B 2	1	50	10
GPK 500/2NL FU	-	1000	800	630	500	-	0.3/3.5	0.6/3.5	80 B 4	2	50	10
GPK 500/2N FU	-	1000	800	630	500	-	0.7/6.9	1.4/6.9	80 B 2	2	50	10

## Model GP with frequency inverter (FU)

### 1 Description

Chain hoists with a frequency inverter are especially applied when a high duty cycle and/or accurate positioning is required. Generally, standard devices as well as the special models can be equipped with a frequency inverter. Beneficially, a four pole stator is used. The two speeds are created by the frequency inverter. The acceleration time as well as the lifting speed can be set individually. The operation station consists of a two stage push-button control. Due to the radio interference filter, the chain hoist corresponds with the EMC directive EN61000 industrial sector (class A).

**Model GP with frequency inverter (see figure 1-1):**

Figure 1-1

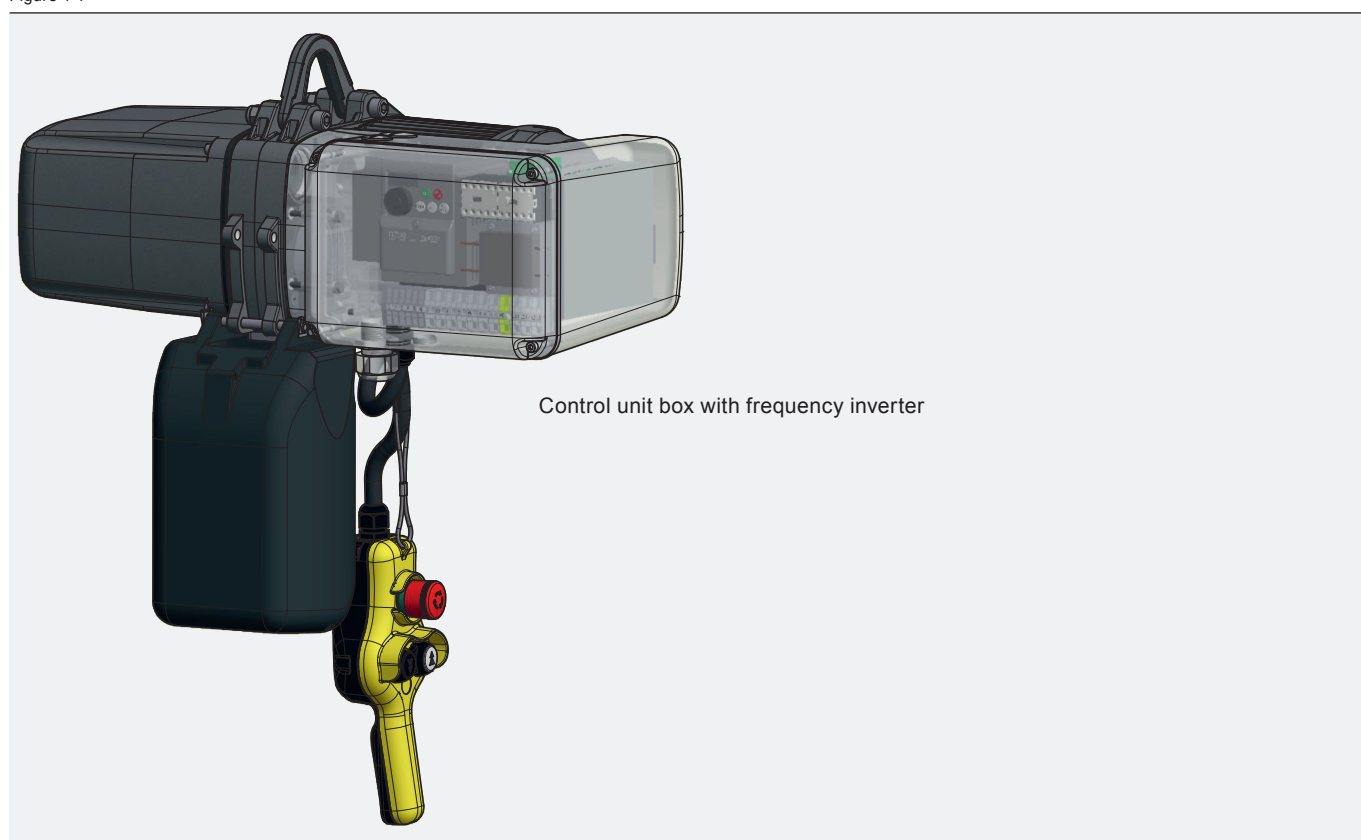

## 2 Start-up

### 2.2 Connecting

#### 2.2.1 Electrical connection

The control voltage of the frequency inverter is 24 VDC. When pressing the emergency stop button, the frequency inverter is switched off from voltage. Electrical diagram of chain hoist (see figure 2-1).

Figure 2-1

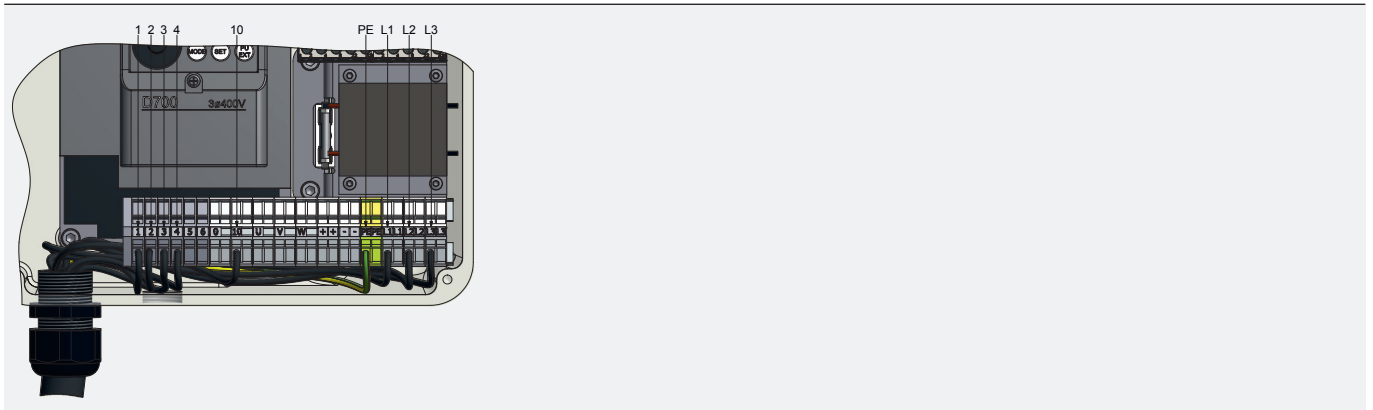

The acceleration time and deceleration time as well as the lifting speed can be adapted to the customers' requirement. The corresponding parameters are only to be changed by qualified personnel.

Parameters	Meaning	Setting range	Factory setting GIS
4	Rotational speed on, slow	8 - 40 Hz	15 Hz
5	Rotational speed down, slow	8 - 40 Hz	15 Hz
6	Rotational speed fast	40 - 87 Hz	87 Hz
7	Acceleration time	1 - 10 s	1 s

A short instruction for operating the frequency inverter is included in the delivery.

# 5 Appendix

## 5.1 Technical data

Table 5-1 Technical data GP FU (three-phase version)

ISO (FEM) classification	M6 (3m) 300 s/h 50% duty	M7 (4m) 360 s/h 60% duty	M7 (4m) 360 s/h 60% duty	M7 (4m) 360 s/h 60% duty	M7 (4m) 360 s/h 60% duty	M7 (4m) 360 s/h 60% duty	Lifting speed 15/87 Hz	Performance FU	Motor type	No. of chain falls	Dead weight 3 m lift	Mains fuse (400 V, delayed)
Types	Capacity [kg]						[m/min]	[kW]			[kg]	[A]
GP 250/1NL FU GP 250/1N FU	320 320	250 250	200 200	160 160	125 125	100 100	1.3/6.9 2.4/13.9	2.2 2.2	80 B 4 80 B 2	1 1	25 25	10 10
GP 250/2NL FU	630	500	400	320	250	200	0.6/3.5	2.2	80 B 4	2	26	10
GP 500/1NL FU GP 500/1N FU	630 630	500 500	400 400	320 320	250 250	200 200	1.3/6.9 2.4/13.9	2.2 2.2	80 B 4 80 B 2	1 1	27 27	10 10
GP 500/2NL FU GP 500/2N FU	1250 1250	1000 1000	800 800	630 630	500 500	400 400	0.6/3.5 1.3/6.9	2.2 2.2	80 B 4 80 B 2	2 2	29 29	10 10
GP 1000/1NL FU GP 1000/1N FU	1250 1250	1000 1000	800 800	630 630	500 500	- -	1.3/6.9 2.4/13.9	2.2 2.2	90 B 4 90 B 2	1 1	63 63	10 10
GP 1000/2NL FU GP 1000/2N FU	2500 2500	2000 2000	1600 1600	1250 1250	1000 1000	- -	0.6/3.5 1.3/6.9	2.2 2.2	90 B 4 90 B 2	2 2	67 67	10 10

# Model GP as an ATEX model (D/G)

## 0 General instructions

### 0.2 General safety regulations and organisational measures

The ATEX model of the chain hoists is visible by its labelling. D is the labelling for "dust" and G for "gas".

#### 0.2.1 Warning markings / Legends / Warning signs

- ATEX dustproof model.....figure 0-1
- ATEX gasproof model.....figure 0-2

Figure 0-1

Figure 0-2

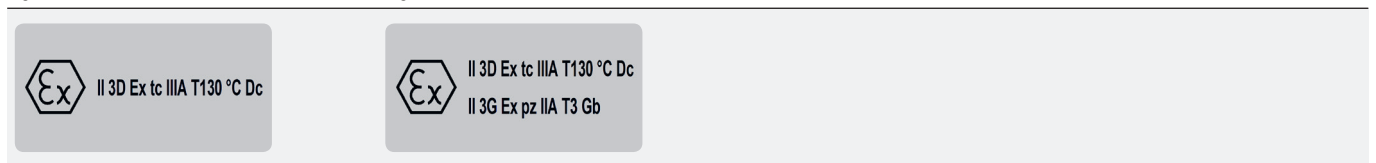

### 0.6 Intended use

The electric chain hoists as an ATEX model are only to be used as intended on the label of the chain hoist and in the conformity documented area. At the original device, no changes are to be performed without consulting the manufacturer.

This standard differs between two types of ranges of application:

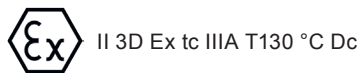

Devices for the range with flammable dust of zone 22. They correspond to group II and device category 3D. Maximum surface temperature is T = 130 °C.

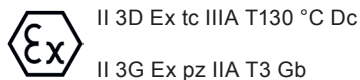

Devices for the range with flammable dust of zone 22. They correspond to group II and device category 3D. Maximum surface temperature is T = 130 °C. For explosive gas atmospheres is zone 2. They correspond to group II and device category 3D and have the ignition protection type Ex pz.

# 1 Description

The chain hoists as an ATEX model have to correspond mandatorily to the protection zone defined by the customer. The declaration of conformity includes the serial number of the chain hoist and the corresponding model.

Execution D: Temperature monitoring prevents the surface temperature from rising above the default value. The protection class IP 65 protects the device and prevents the intrusion of explosive dust.

Execution G: The electric control in explosive gas atmospheres only work when positive pressure (approx. 0.4 bar) is available in the housing. The positive pressure is controlled by a pressure switch. With that, the connection pressure is reduced from 4-10 bar to 0.4 bar. Temperature monitoring prevents the surface temperature from rising above the default value. The protection class IP 65 protects the device and prevents the penetration of explosive dust.

**Model GP as a dustproof model (see figure 1-1) and as a gasproof model (see figure 1-2):**

Figure 1-1

Figure 1-2



## Options:

- Control switch: A control switch with a certificate for the same zone as the chain hoist is available for ATEX models. In certain areas, the GIS standard control switch with protection class IP 65 is sufficient for model D.
- Motorized trolleys are available for the same ATEX models as the electric chain hoists.

## 2 Start-up

### 2.2 Connecting

#### 2.2.1 Electrical connection

The start-up of model D takes place as for a standard chain hoist. The start-up of model G takes place according to figure 2-1.



For model G, a compressed air supply of 4-10 bar is required for the start-up. The pluggable nominal diameter of the air connection is 6 mm. It is to be ensured that perfectly maintained **non explosive** compressed air is supplied. A pressure reduction valve creates a positive pressure of approx. 0.4-0.5 bar in the interior of the chain hoist. If this positive pressure decreases or is not established yet, the control voltage is interrupted. The settings of the pressure monitoring are set from the factory and sealed. If these settings are changed without consulting, the warranty is inapplicable.

Figure 2-1

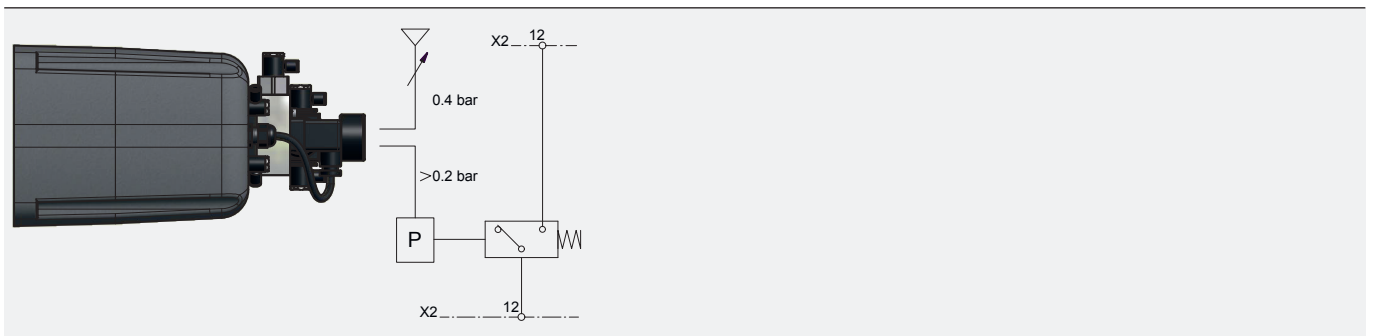

## 3 Care and maintenance

### 3.1 General guidelines for maintenance and servicing



Maintenance is only to be performed outside the explosive zones.

# Model GP with radio remote control

## 1 Description

Transmitter and recipient are designed robust and compact. The handheld transmitter is equipped with a rechargeable lithium-ion-battery and has the protection class IP 66. The receiver, integrated in a stable housing, has protection class IP 65. The pluggable construction allows a fast replugging for emergency operation e with the control switch. With its certified STOP function the receiver meets the requirements of SIL 3 Performance Level PL e.

Many options can be reprogrammed easily and fast. To each chain hoist with radio remote control, a separate instruction manual for the radio remote control is enclosed.

**Model GP with radio remote control (see figure 1-1) and handheld transmitter (see figure 1-2):**

Figure 1-1

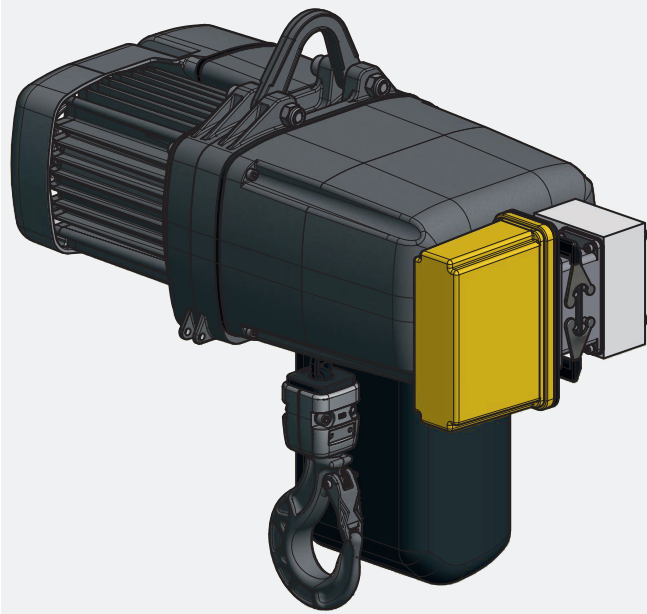

Figure 1-2





## 2 Start-up

### 2.2 Connecting

#### 2.2.1 Electrical connection

Wiring diagram of plug connection of standard execution (see figure 2-1) and of execution with frequency inverter (see figure 2-2).

Figure 2-1

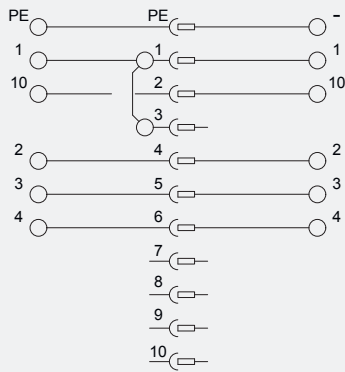
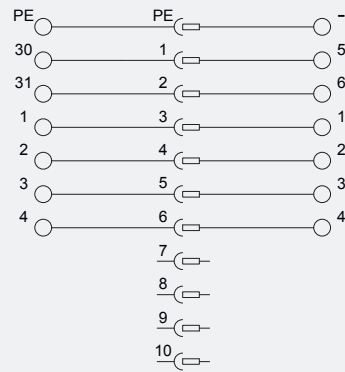

Figure 2-2



The standard radio remote control is designed for a operation voltage of 42 VAC. Please ensure that the operation voltage of the radio remote control corresponds to the control voltage. When switching on the machine, visual contact with the chain hoist must be made.

- After applying operation voltage at the electric chain hoist, the pluggable recipient is to be plugged in at the 10 pole plug (see figure 2-3).
- Control if the stop button is pressed (see figure 2-4).
- Pull out the stop button. LED 0 lights green (when battery capacity is good) or red (when it is low). In this case, the battery needs to be fully harged first (see figure 2-5).
- Press button SR and SL simultaneously. The buzzer beeps (see figure 2-5).
- Release start buttons. The buzzer stops beeping.
- The radio remote control is ready for operation. LED 0 lights green. The handheld transmitter will switch off if no radio communication is established within 25 seconds.

Figure 2-3

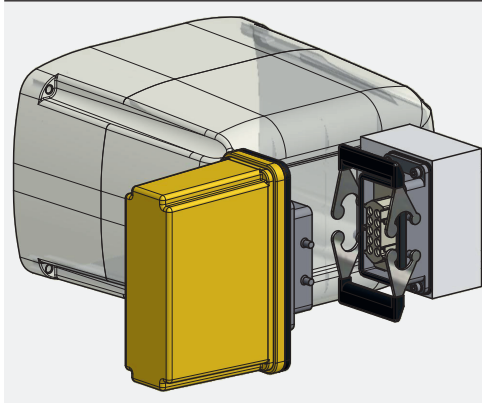

Figure 2-4

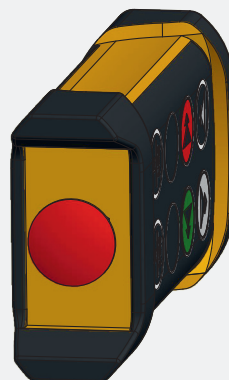

Figure 2-5



# 5 Appendix

## 5.1 Technical data

Table 5-1 Technical data radio remote control (general)

Range of application	Lifting equipment safety level SIL 3, PI e
Frequency	433 MHz (69 channels)
Radio remote type	Low IF topology
Coding	Digital pulse code

Table 5-2 Specifications radio remote control (handheld transmitter)

Function	4 x two-stage, On/Off
Output power	10 mW (50 Ohm)
Antenna	Integrated
Power supply	fixed battery (Li-Ion)
Operating period	approx. 24 hours continuous operating
Power consumption	approx. 45 mA
Weight	approx. 295 g
Protection class	IP 66
Recommended recipient	TG-R10-1-1

Table 5-3 Specifications radio remote control (recipient)

Sensitivity	approx. 110 dB at 1/100 PER
Relay outputs	7 function relays, max. load 8 A
Antenna	Integrated
Weight	650 g
Dimensions	152 x 139 x 58 mm, pluggable
Protection class	IP 65
Recommended transmitter	TG-T9-1

# Model GP with temperature monitoring

## 1 Description

### **Klixon (see figure 1-1):**

A thermocouple with a temperature-sensitive N/C contact is fixed on the winding head of the stator. In case of overheating, the control current is interrupted and switches off the chain hoist voltage. After a longer cooling time, the chain hoist can be used again.

### **Cold conductor with trigger unit (see figure 1-1 and figure 1-2):**

A temperature-dependent resistor fixed on the winding head of the stator interrupts the control voltage via a relay (trigger unit) in case of overheating. This reliable temperature monitoring can be mounted in external control systems. It is especially applied when the application of the chain hoist is not monitored permanently.

Figure 1-1

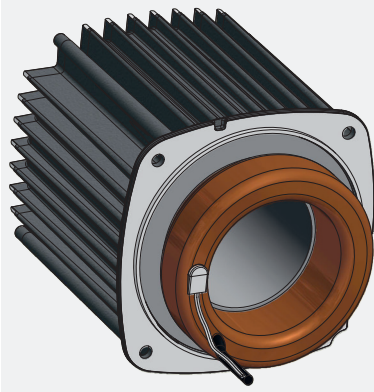
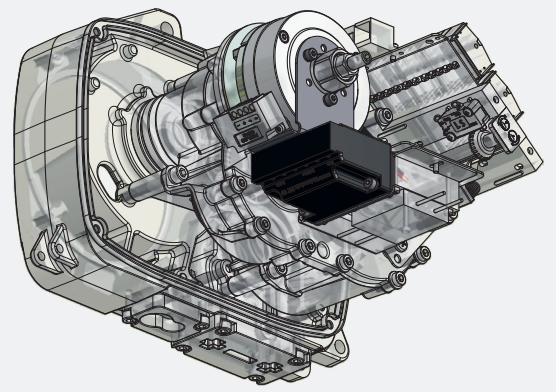

Figure 1-2



# Model GP with operating data counter

## 1 Description

The operating data counter can be retrofitted to a chain hoist with 42 V control voltage at any time. By determining the application, the factor for determining the operating hours can be reduced. This tool is especially applied for mobile use or rented hoists.

### Operating hours counter:

- Internally, operating seconds are counted
- Inputs: Up, Down, Fast
- counts the seconds when input Up is active or counts the seconds when input Down is active

After one operating minute the counter value is saved in operating seconds. If the operating minute has not been reached after one minute, the remaining operating seconds will still be saved.

### Event counter:

- Inputs: Up, Down, Fast
- per switches one event is counted

The counter value is saved when the operating-hours counter is saved.

### Model GP with operating data counter (see figure 1-1):

Figure 1-1

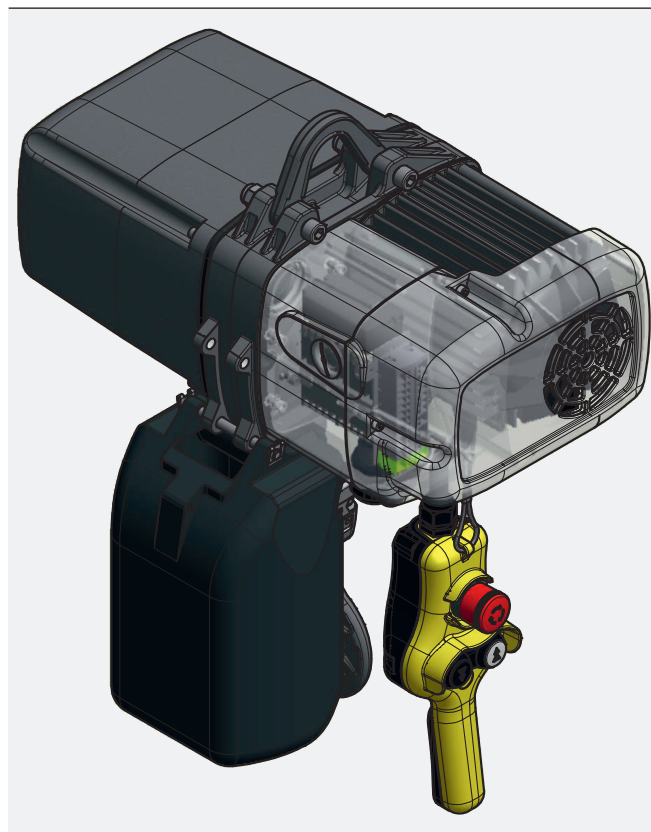
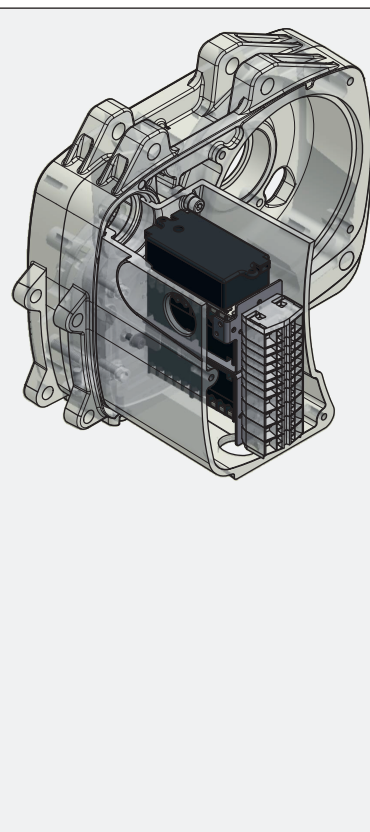

Figure 1-2



### Mounting in electric chain hoist (see figure 1-2):

The black housing is stuck on the conductor combination by double-sided adhesive tape and the strands are connected to terminals 1-4 and PE.

## 2 Start-up

### 2.2 Connecting

#### 2.2.1 Connection electric (see table 2-1)

Connection cross-section of strands: 0.5 mm<sup>2</sup> outside diameter (isolation): 1.6 mm

Table 2-1 Connections hoist control

Pin	Function	Labelling	Notes
1	Supply	1	42 VAC
2	0 V	7	0 VAC
3	UP (Signal)	2	42 VAC
4	DOWN (Signal)	3	42 VAC
5	FAST (Signal)	4	42 VAC



The connections are labelled on the circuit board (see figure 2-1).

#### Service interface:

The data counter is mounted onto the lower part of the housing and is removed from the chain hoist for reading the data (see figure 2-2).



Reading the data during operation is prohibited and can lead to the destruction of the device.

Via service interface, the data of the operating data counter can be read with the special Interface Box via USB/RS232 Interface. The data can be visualized on a PC by using a small software. The software can be requested from the manufacturer.



Pin 1 is labelled on the circuit board (see figure 2-3).

Figure 2-1

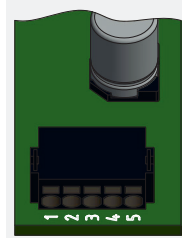

Figure 2-2

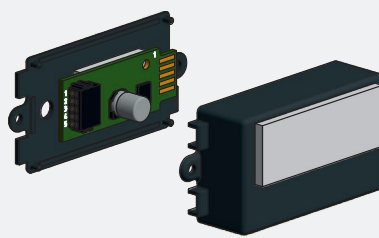
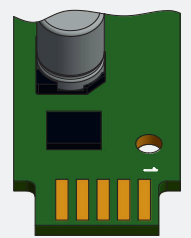

Figure 2-3



### Reading device (see figure 2-4):

The data of the operating data counter are directly transmitted to the hand device via reading device and shown on the display. The reading device can be ordered at the manufacturer. For starting-up the reading device, 4 batteries 1,5 V type AA are to be inserted into the housing.

Reading data:

1. Connect the operating data counter with the connection cable of the reading device.
2. Press the button.
3. The data can now be read from the display.
4. The reading device can be switched off by pressing and holding the button.

Figure 2-4



### Reading device software:

Installation:

Create the folder C:/GIS\_Betriebsstundenzaehler and copy the two files

- putty.exe
  - Betriebsstundenzaehler.bat
- to C:/GIS\_Betriebsstundenzaehler.

Reading data:

1. Connect the USB cable of the USB to BSZ interface to a free USB port on your computer.
2. Connect the operating hours counter to the connection cable of the USB to BSZ interface.
3. Turn the switch to position "ON".
4. Open device manager:
  - Version A:  
Press [Windows key] + R. Type "devmgmt.msc" and confirm with [Enter]. The device manager is opened.
  - Version B:  
Open the Start Menu, go to "Device manager" and click to "Device manager".
5. Open the connections and search for the USB Serial Port. Keep in mind the port number.
6. Start C:\GIS\_Betriebsstundenzaehler\Betriebsstundenzaehler.bat. If you don't start the programme for the first time and would like to use the same port, press [Enter]. If the programme is run for the first time or you would like to choose a different port, enter the port number in format COMx and confirm with [Enter].
7. Press the [ENTER] key until "BUGGY>" lights up. Now the data with the following terminal commands can be read:
  - "version" (display the version of the programme)
  - "data" (indicates the number of counting impulses and the total time of usage)



Switching on the supply indicates the number of counting impulses and the total time of usage.

# 5 Appendix

## 5.1 Technical data

Table 5-1 Technical data operating data counter

Parameters	Value
Supply voltage	42 VAC $\pm$ 10%, 50/60 Hz
Voltage control signal	42 VAC $\pm$ 10%, 50/60 Hz
Operating seconds	1 sec. $\pm$ 2% @ 0 ...70° C

Table 5-2 Configuration RS232 interface

Baud rate	9600 Baud
Number of data bits	8
Parity	None
Flow control	None

